

MAURER Products for Railway Structures



Product Overview and Relevant Specifications and Approvals

Maurer Product	Specifications and Approvals
DB40	German Railway Directive Drawing MBR 1965 Features: watertight, maintenance free, long service life. For joints under ballast
DB80	German Railway Directive Drawing MBR 1966
DB130	German Railway Directive Drawing MBR 1967
Elastoblock D80E-n	German Railway Directive Drawing MBR 1961
Longitudinal Joints	German Railway Directive Drawing MBR 1968
Open Joint/Ballast	German Railway Directive Drawing MBR 198-10 (non-proprietary)
Open Joint w/o Ballast	Proprietary specification concerning watertight and maintenance free expansion joints
Railway Turnout	Registered Design DE 299 24 361 U1 issued by German Patent Authority
Spherical Bearings	German Approval Z-16.4-316
Spherical Bearings MSM	<ol style="list-style-type: none"> 1. German Approval Z-16.4-436, for fast and frequent displacements 2. European Technical Approval ETA-06/0131 <div style="text-align: center;">  <p>Deutsches Institut für Bautechnik Anstalt des öffentlichen Rechts Kolonnenstr. 30 L 10529 Berlin Germany Tel.: +49(0)30 787 30 0 Fax: +49(0)30 787 30 320 E-mail: dibt@dibt.de Internet: www.dibt.de</p> <p>European Technical Approval ETA-06/0131</p> <p>English translation prepared by DIBt - Original version in German language</p> <p>Handelsbezeichnung: MAURER MSM® Kalottenlager Trade name: MAURER MSM® Spherical Bearing</p> </div>
Sliding Bearings (Pot and Elastomeric)	German Approval Z-16.2-318, concerning the design of the sliding components
Bridge Bearings for Maglev Train	Type Approval issued by German Railway Institute, dated September 22, 2003
Elastomeric Bearings	Ri804 issued by German Railways, specifying, among others, the requirements for elastomeric bearings for railway bridges
Pot Bearings with pad made of natural rubber	German Approval Z-16.2-423
MSM Sliding Material	<ol style="list-style-type: none"> 1. Material certificates type 3.1A issued by MPA Stuttgart that comply to the requirements acc. German Approval Z-16.4-436 issued by the German Institute of Civil Engineering and also comply to EN 1337-2 2. Test report M3868 issued by IKP Stuttgart concerning the chemical stability of MSM
Sealing Elements	EN 1337-5, category c
Shock Transmitters	On request to be equipped with force limiter, thus limiting the maximum force to be transferred to a defined value.
Hydraulic Dampers	Highest energy dissipating capacity of all dampers in the market

0 Introduction

Railway bridges are different, because the trains that pass bridges bring about different requirements as compared to road bridges. When trains pass, the traffic loads are higher, and in case of High Speed Railways the passing traffic is considerably faster than conventional road traffic.

As a consequence, products that are suitable for the use in road bridges might not be equally suitable in railway bridges.

Below shall be demonstrated that MAURER SÖHNE has a complete product range of bridge accessories in their scope of supply, which especially cater for the requirements of railway traffic.

1 Railway Expansion Joints

1.1 The DB Joint Series

MAURER type DB expansion joints essentially consist of 5 elements (Fig.1.1):

1. A mat section that absorbs the movement of the structure.
2. A clamping section which prestress the mat section and thus provides a watertight fixing.
3. A substructure anchored to the adjacent structures, in the form of angle sections that are concreted in or welded.
4. A screw fixing to apply prestressing.
5. An elastomer sealing to connect the DB railway joint to the waterproofing layer of the bridge deck.

DB 40	± 20	± 40	± 20
DB 80	± 40	± 60	± 40
DB 130	± 65	± 100	± 65

Table 1 Maurer DB Movement Joint Types

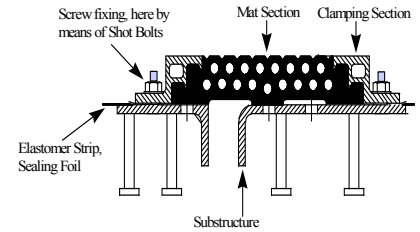
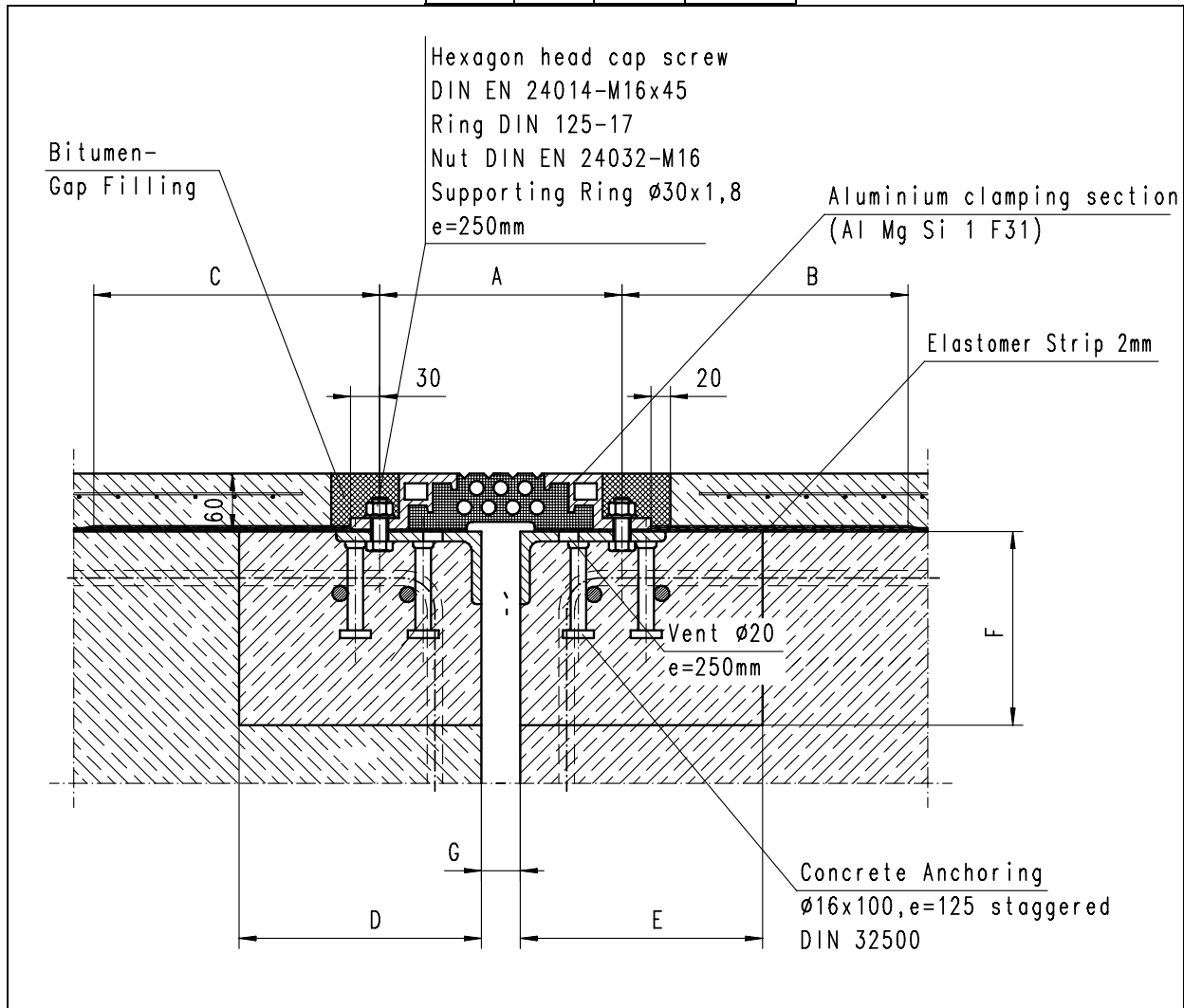

Fig. 1.1 Design Principle of a Maurer DB Joint

Installation of the DB joints, conventional style

The conventional way of installing the joints is such that the complete DB-joint is being manufactured in

TYPE	Movement Capacity in mm		
	Longitud.	Lateral	Vertical



Dimensions (mm) For Joint Type	Distance between screws A	Elastomer Strip Overlap B	Elastomer Strip Overlap C	Blockout Width D	Blockout Width E	Blockout Depth F	Structural Gap G
DB40	250±20	300	300	>250	>250	200	40±20
DB80	375±40	300	200	>250	>450	200	50±40
DB130	475±65	300	300	>250	>450	200	70±65

Fig. 1.2 Dimensions of conventional DB joints that will require a block out for installation.

the workshop (i.e., both superstructure and substructure of the joint, as it is displayed in Fig 1.2 above). This complete joint is then lifted into the blockout, connected to the existing reinforcement, and the blockout will then be concreted

Installation of the DB joints, Alternative Method

The installation sequence that is shown below was originally developed to cater to the special requirements of the Korean High Speed Railway Project.

Main focus was to develop a solution that enables an installation for precast segments, which held a number of conditions:

- Joint substructure to be embedded into the precast

segments at the time of casting these segments

- Guaranteeing a transversal construction tolerance of at least 10mm
- Gap width at time of installation 30mm
- Spacing of the anchor bolts such that they will not interfere with the longitudinal reinforcement of the top slab

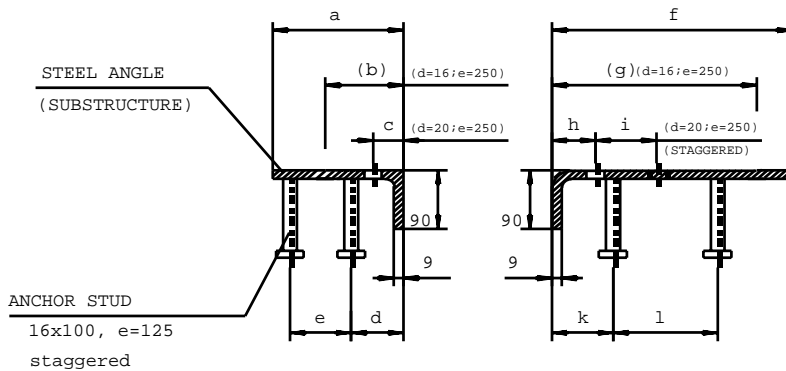

g and b depict the future location of the welded studs
c, h and i depict the location of the air holes

	a (mm)	b (mm)	c (mm)	d (mm)	e (mm)	f (mm)	g (mm)	h (mm)	i (mm)	k (mm)	l (mm)
DB 40	150	105	40	60	70	150	105	40	---	60	70
DB 80	150	90	25	60	70	275	235	60	70	70	120
DB130	150	90	25	60	70	355	315	100	100	80	220

Fig.1.3 Dimensions for embedding the substructure in a precast segment



Fig.1.4a: Above: Alternative installation method, example Korean High Speed Railway: Applying the sealing foil and connecting the sealing foil with the adjacent waterproofing layer of the bridge deck



Fig.1.4b: Fixing the mat section with the aluminium clamping section on top of what can be seen left

VULCANISING OF DB MATS AND CONNECTION WITH LONGITUDINAL JOINTS

Maurer DB joints can take any shape, by vulcanising the mat sections.



Fig.1.5A: Humbolthafen Berlin, Germany: Vulcanised T-piece that is being prepared to receive another vulcanised butt joint connection on site with a longitudinal DB joint.



Fig.1.5B A conventional longitudinal joint connected to a DB mat (Humbolthafen Berlin, Germany)

1.2 The Elastoblock Joint for Railway Tracks

The Elastoblock Joint dates back to the early 1980s, when the first bridges for the German High Speed Railway were built in Germany.

MAURER developed a unique neoprene seal that follows the MAURER philosophy. It employs the following features:

- absolutely watertight
- maintenance free (particularly in respect to the corrosion prone screwed connections)
- long service life (fatigue tested)

A special feature is the capability of post-adjustment. Long holes in the steel section enable the joint to

be post-adjusted for up to +/- 15mm.

The Elastoblock joint can be considered as low cost alternative to the technically more sophisticated DB joints.

General Approval of the German Railway Authority

This Elastoblock Joints enjoys the approval of the German Railway Authority, for the use of railway joints (under ballast).

Main area of application of the Elastoblock joint are straight joints with a movement of a maximum of 80mm. The Elastoblock joint can be adapted to almost all national regulations and conditions on site.

Reference projects

The Elastoblock joint has been installed in a variety of bridges for the High Speed Railway link between Würzburg and Hannover.

As for the conventional railway lines, Maurer has executed numerous projects, both on national and international level., for example in Austria, Belgium and Iraq.

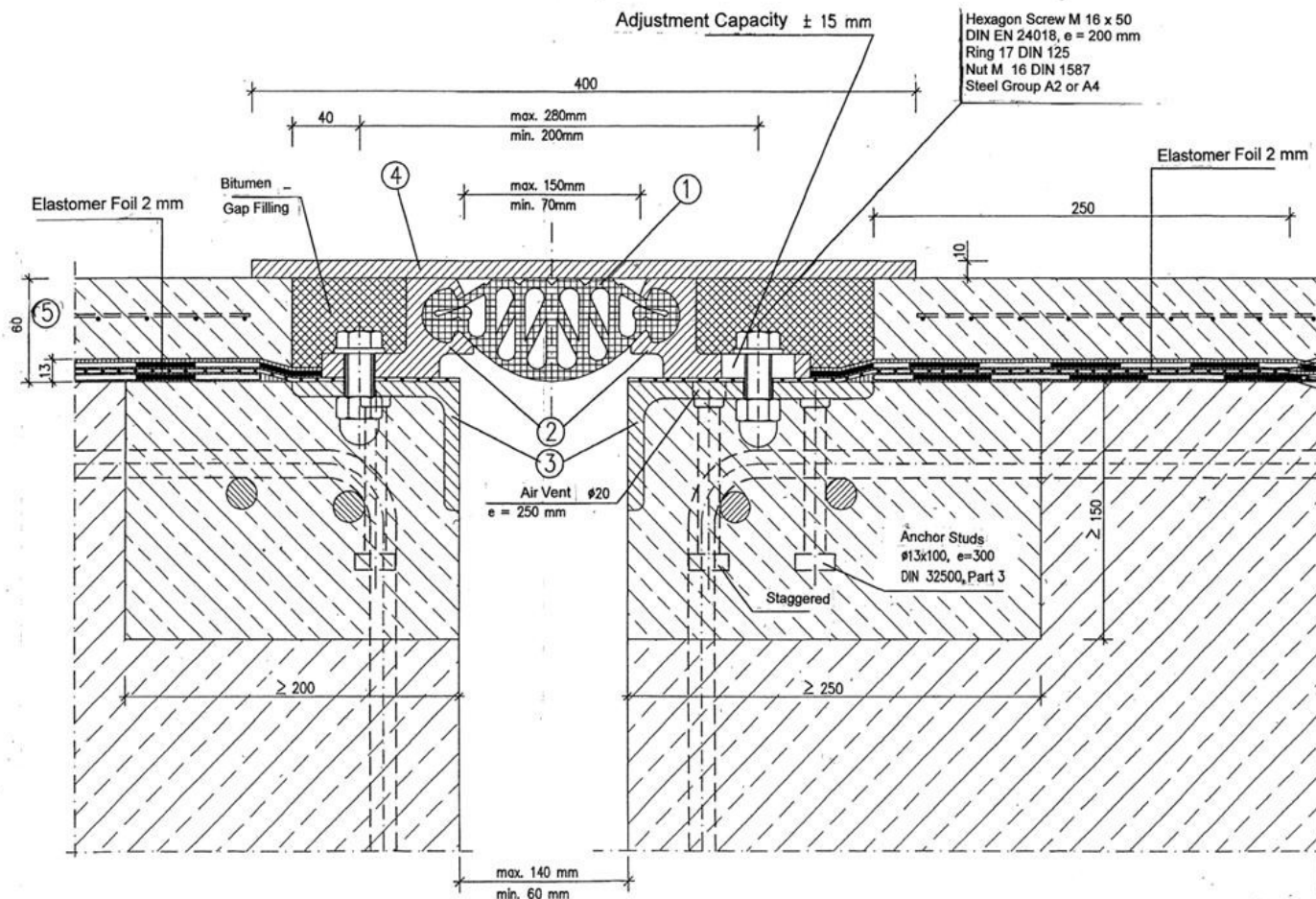

Fig. 1.6 Extract of directive drawing #M-ÜF 1961 issued by German Railways. It depicts the Maurer Elastoblock Railway Joint Type D80E-n, featuring an adjustment capability of the rubber seal, e.g. for presetting.

German Railways adds the following explanations for #1 - #5, as displayed above:

- (1) Movement capacity of the rubber mat, if the rubber mat is preset by 20 mm, which corresponds to a width of 110 mm (uncompressed = 130 mm): in all 3 directions ± 40 mm.
- (2) The steel profile can be loosened and readjusted at one side
- (3) Corrosion protection according to directive drawing M-ÜF 1920
- (4) Protective plates made of rubber granulate, like for example polyurethane-rubber or highly compressed rubber granulate (Shore A > 45, density > 800 kg/m³, d = 10 mm)
The protective plates shall be provided by the contractor, and not by the manufacturer of the expansion joints.
- (5) In case of bridge structures for the high speed railway track, the thickness of the protective concrete incl. waterproofing layer shall be 80 mm.

1.2 Expansion Joints for Ballastless Tracks

Whereas the Maurer Elastoblock and DB expansion joints cater for railway tracks under ballast, in cases where no ballast will cover

the expansion joints, technically simpler solutions can be proposed. In that case, the anchorage of the expansion joint will not be subject to traffic loads, and the joint only needs to be watertight.

Depending on the specification of the customer, Maurer can offer a wide range of low cost solutions. One of the possible solutions is displayed below:

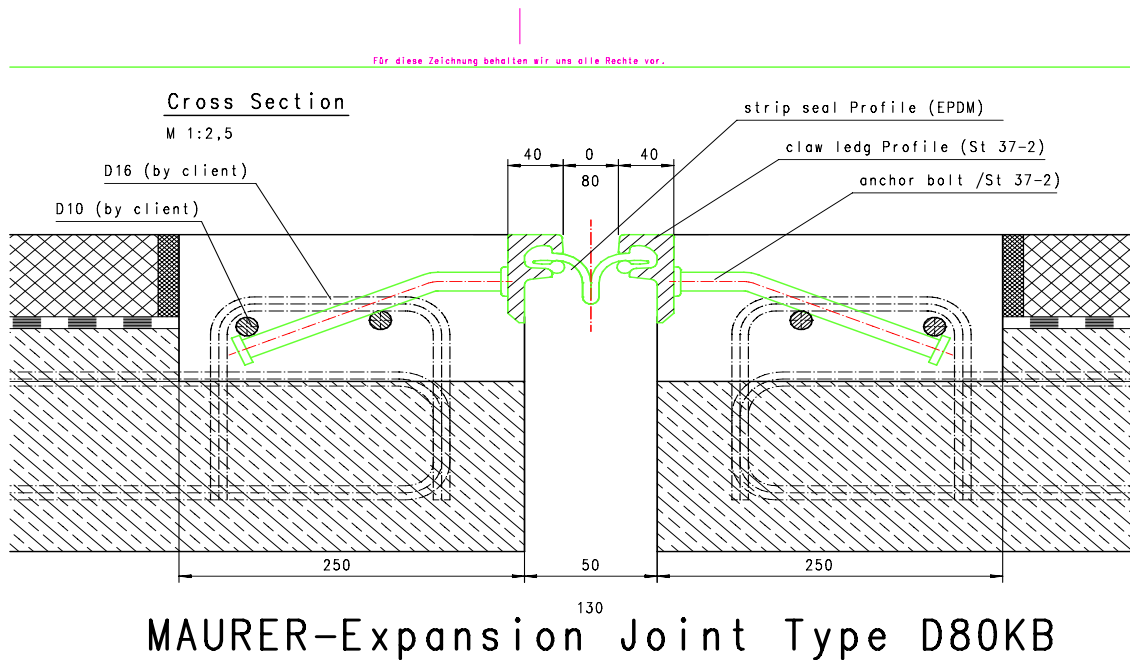

Fig. 1.7 Expansion Joint for a ballastless track

The proposed solution according Fig. 1.7 depicts a standard single seal expansion joint with a movement capacity of 80 mm (depending on the size of the sealing element, up to 200 mm movement capacity is possible). Anchor studs as anchoring element are fully sufficient, since the expansion joint will not be subject to major traffic loads. Water tightness will be achieved by the well-proven sealing element, which is successfully installed in countless road bridges.

1.4 Open Joints

The German Railways limits maximum movement of a

ballasted mat type expansion joints to 130 mm. Reason is that movements beyond 130 mm would cause settlements in the ballast that covers the joint, which is not acceptable. Thus, for movements beyond 130 mm, alternatives have to be devised.

In case that the movement of a railway expansion joint under ballast should exceed 130 mm, a so called open joint is required. Strictly speaking, an open joint is not an expansion joint that links 2 ends, but it can be understood as a steel construction that locks up the ends of the bridge deck,

respectively the abutment, thus creating a structural gap (void) between the 2 edges, which shall be crossed by the rails.

The rails that are situated on top of the open joints are also subject to such a major movement, and are too rigid to compressions or extensions in the elastic range of the stresses. Consequently, the rails also need to be separated in a way that the rails can perform the movement without impeding the railway traffic. This is achieved by so called railway turnouts (see next chapter)

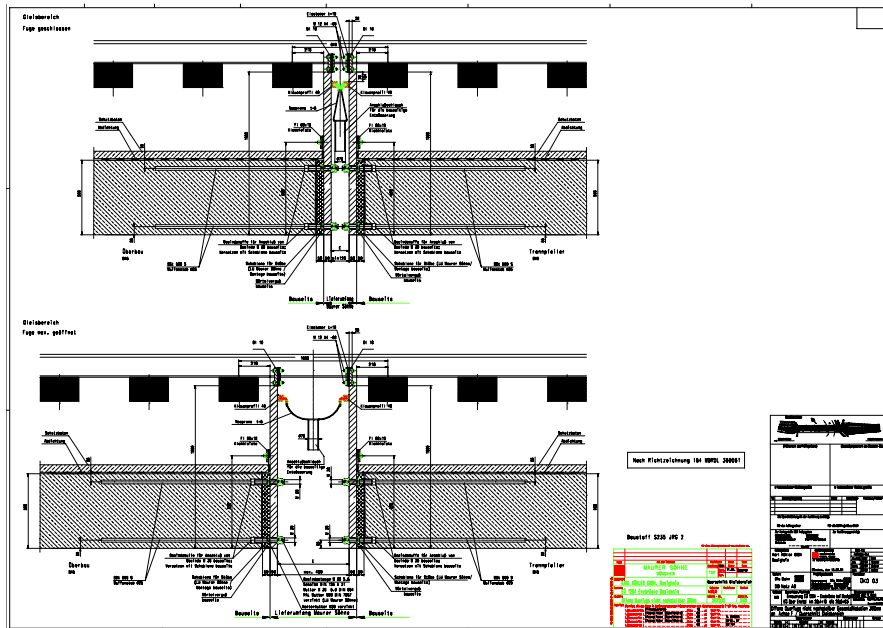

Fig. 1.8 Open joint, in closed and fully opened position, as specified by German Railways

1.5 Railway Turnouts

A railway turnout is not designed to cover or bridge any structural gap, but it shall enable the rails to expand and contract, according to the movements of the bridge.

Maurer has developed and patented railway turnouts for movements of up to 160 mm. For bigger movements, project specific solutions will be proposed.

The sketch below depicts a railway turnout catering for a movement of up to 160 mm.

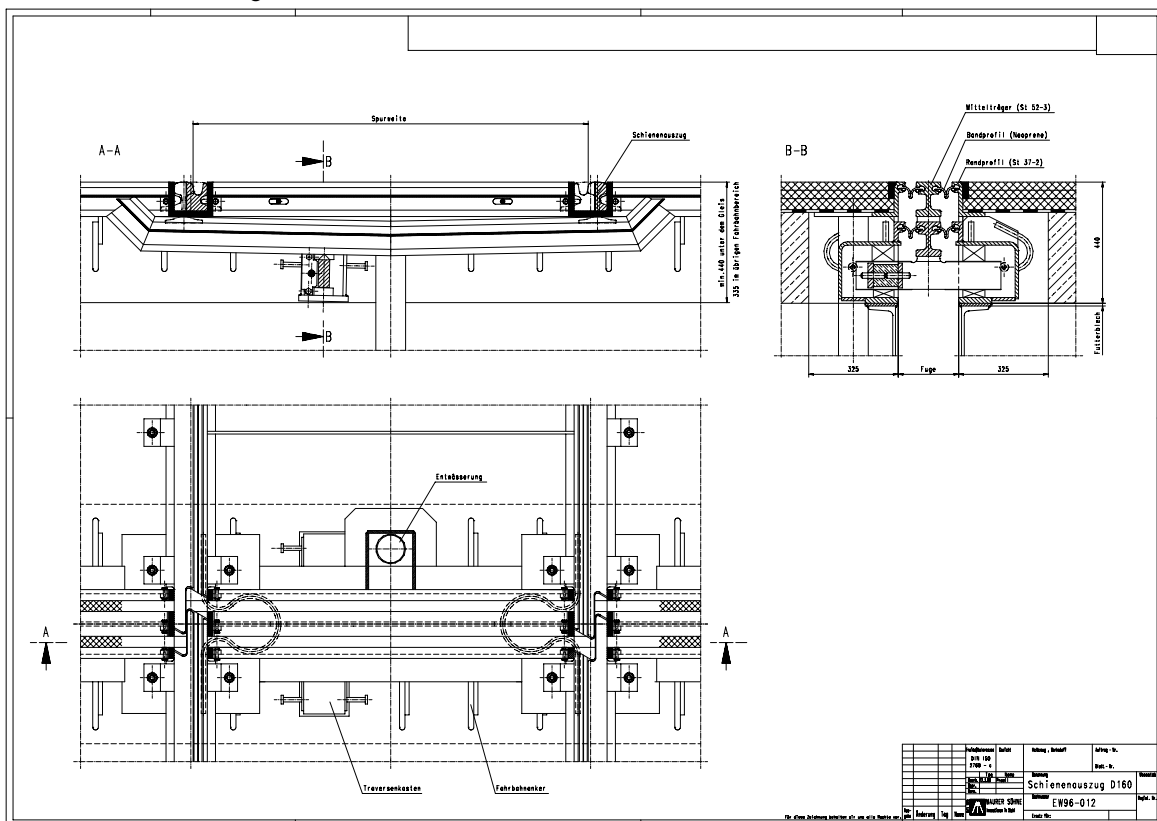

Fig. 1.9 Railway turnout catering for a movement of 160 mm

2. Railway Bridge Bearings

In railway bridges, the relationship of live load to total load is relatively high. So each time a train passes, the additional load is relatively high, causing considerable movements and reaction forces in the bridge bearings. Among others, the rotation of the bridge bearing due to live load is considerably higher, also any sliding movement caused by live load is of a bigger magnitude than in road bridges. In bridges for High Speed Railways, these movements are carried out in a very short time. It is most extreme in the Maglev Train that poses extraordinary challenges for bridge bearings.

2.1 Spherical bearings

Spherical Bearings enjoy a variety of advantages over conventional pot bearings, when it comes to the use for railway bridges:

- Spherical bearings contain no elastomeric pad, so in case of rotation no major restoring moment due to resistance of rubber to be compressed need to be considered for the design of the bearing, but only a

negligible constant one caused by friction forces.

- Because spherical bearings contain no elastomeric pad, they therefore need no sealing element which is the limiting factor for the life time in pot bearings.
- No elastomeric pad also means that the permissible pressure in the bridge bearing is no longer governed by the permissible pressure in the elastomeric pad, which in most cases is the limiting factor for the size of the bearings.

In other words, from a certain given load upward, spherical bearings can be manufactured smaller, and thus more economically

A new dimension in high performance bearings can be reached when spherical bearings are combined with MSM as sliding element, instead of PTFE. In that case, performance at low temperatures is greatly enhanced due to a reduced coefficient of friction. Further, MSM facilitates a higher sliding velocity. Last but not least, the MSM spherical bearings can take higher stresses than conventional PTFE sliding

bearings, resulting in smaller dimensions, making the spherical bearing more economic.

The advantages of MSM will be described in detail in the corresponding section.

Spherical bearings in combination with MSM as sliding material have been approved by a range of national authorities, and first reference projects confirm the superior performance of MSM-spherical bearings. Among others

- French TGV High Speed Railways have recognised the many advantages that MSM employs over conventional PTFE – thus the development of MSM triggered a first time approval of the use of spherical bearings in the French TGV High Speed Railway. (Before, only pot bearings were specified)
- Spanish High Speed Railway, first reference project due to the enormous savings potential in the bridge structure, when MSM is employed
- Approval in Russia for the general use in bridge bearings (by FZS, Gosstroj Rossii), with first reference projects in Russia
- European Type Approval (ETA)

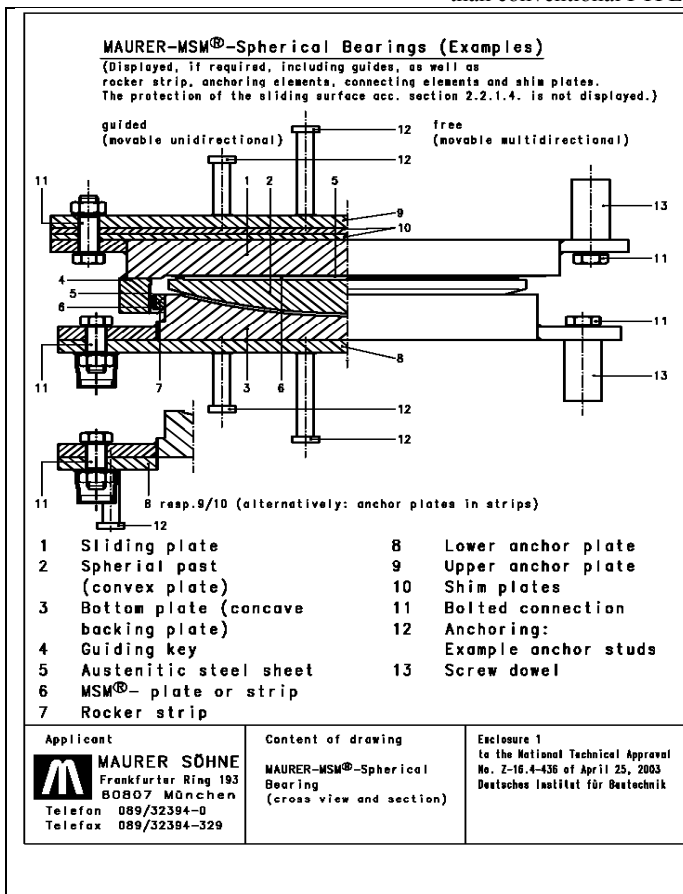

Fig. 2.1 (left) Principle sketch of a Maurer spherical bearing – extract from the German MSM approval document

Fig. 2.2 (above) Lower part of a spherical bearing with MSM, to be employed for the Subway in Moscow

2.1.2 UPLIFT BEARINGS

Maurer has developed special spherical bearings that are designed for transferring uplift forces. For example, bearings of the design type as shown below were installed at the new central railway station in Berlin (Lehrter Bahnhof)

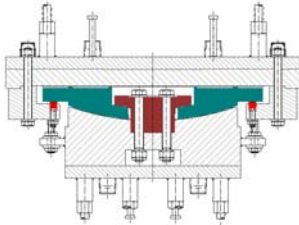

Fig. 2.3 Principle sketch of a spherical bearing designed to accommodate uplift forces

2.2 MSM – a New Sliding Material Especially Suited for High Speed Railways

2.2.1 GENERAL

In railway bridges, where the relation of traffic load to the total load is higher than in road bridges, consequently the rotation of the superstructure and thus the one of the bridge bearing is higher than in road bridges. In addition, due to their high speed motion, high speed railways cause the rotations of the bridge bearings to occur

much faster than it is the case with road bridges. Speed of movement is therefore the characteristic strain onto bearings for high speed railway bridges. Further, over the service life of bridge bearings, frequent rotations and deflections cause considerable total sliding displacements. It can already be observed that bearings with conventional PTFE as sliding material cannot cope with these requirements, causing maintenance problems. As can be

shown, the sliding bearings that have to cater for these special requirements of fast and frequent movements, need to be upgraded with a new generation of sliding material that warrants the service life that we are used from conventional sliding bearings.

Fig.2.3 displays the sliding velocity and sliding displacement of a bridge bearing when a high speed train passes:

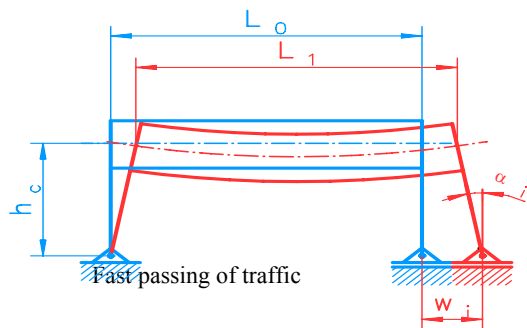

Frequent passing of traffic

→

→

displacement w_i : (symmetric behaviour assumed, no other effects considered)

$$w_i = 2 \cdot h_c \cdot \tan \alpha_1 - \Delta L;$$

$$(\Delta L = L_0 - L_1)$$

short period t_i of displacement:

high mean sliding velocity $v_{i,m}$:

$$v_{i,m} = dw_i/dt_i = w_i / (L_0/v_{train})$$

high accumulated sliding path s_a :

$$s_a = c \cdot \sum w_i \quad \text{with } c = 2$$

(for 2-span girders: $c = 4$)

Numerical Example for a Single Span High Speed Railway Bridge

$L_0 = 60\text{m}$; $\tan \alpha_1 = 0.015$ (concrete girder); $h_c = 3.5\text{ m}$; $v_{train} = 300\text{ km/h}$; $L_{train} = 240\text{ m}$

$w_i = 2 \cdot h_c \cdot \tan \alpha_1 - \Delta L = 11\text{ mm}$ ($\Delta L < 0.5\text{ mm}$, thus negligible); $s_a = 2w_i = 22\text{ mm}$ per passing

$$v_{i,m} = dw_i/dt_i = w_i / (L_0/v_{train}) = 15\text{ mm/s}$$

Fig.2.4 Example of sliding displacement and sliding velocity per each passing of a high speed train

As it can be seen from the example above, PTFE with a tested sliding velocity of 2 mm/s will not be able to cope with such a considerable sliding velocity, i.e. PTFE will display wear in short time.

These particular requirements will, from a certain threshold yet to be defined, exceed the suitability of conventional sliding elements. ,

2.2.2 CASES WHEN DESIGN LIMITS OF PTFE ARE EXCEEDED

The following table compares the design values of PTFE with the ones of MSM, with examples to be followed.

	PTFE	MSM
Displacement velocity tested (acc. EN 1337-2)	2 mm/s	15 mm/s
Accumulated sliding displacement tested (acc. EN 1337-2)	10,242 m	50,000 m
Characteristic contact pressure f_k	90 N/mm ²	180 N/mm ²

Table 2.1 Comparison PTFE - MSM

Further, under identical conditions, the friction coefficient of MSM is below the one of PTFE. In particular in regions of very low temperature the performance of MSM is by far superior than PTFE.

So, if one of the design limits of PTFE is reached, MSM is the material of choice. This will be shown at the hand of 2 examples:

GERMAN MAGLEV TRAIN

For the bridge bearings of the German Maglev Train, potential suppliers had to comply to the following specification:

Design of bearings for a service life of 40 years
 Bearings have to be maintenance free
 80 passings per day
 Design velocity for sliding elements of bearings: 15 mm/sec
 Each passing causes a movement of the sliding elements of ± 5 -10mm
 At the location of the connection of 2 girders, the maximum dislocation in vertical direction between the 2 adjacent girders may not exceed 0.1mm after installation and 0.3mm due to wear

If we would assume an average maximum movement of 7.5mm per passing, the accumulated sliding path per each movement would result to 30mm (2 span girder). Total accumulated movement thus will calculate as

$$40 \times 365 \times 80 \times 4 \times 0.0075\text{m} = 35,040\text{m}$$

In addition, when adhering to the relation of wear and the product of sliding velocity v , and contact pressure p , $p \cdot v$, it can be derived that service life would be reduced

by a factor of 7.5 due to the sliding velocity only (actual displacement velocity of 15 mm/sec vs. test velocity of PTFE of 2 mm/s)

All 3 limiting factors result in a high likelihood, if not certainty, that PTFE is not suitable for the use in bridge bearings for a Maglev train.

RIO TEJO BRIDGE, PORTUGAL

Rio Tejo Bridge is a relatively soft double deck suspension bridge, with upper deck for road traffic, and lower deck one for railway. The railways (in this case not in high speed) cause relatively high displacement velocities of the sliding material, as well as a high accumulated sliding displacements.

The bridge was built in the 1960s. Due to constant maintenance problems with the roller bearings,, they were replaced by spherical bearings. The performance requirements for the sliding material were as follows:

- Workable at a displacement velocity of 15 mm/sec
- Total movement per year 9,000m
- Warranty period 5 years

Only spherical bearings equipped with MSM could satisfy above requirements.

MSM in Combination with Pot Bearings

Railway Administrations of many countries have specified the use of pot bearings to be applied in railway bridges, and it may be difficult to suddenly change a specification with the advent of a superior sliding material.

With the limiting factor in pot bearings to be the permissible compressive pressure of the elastomeric pad which is relatively low, of the many advantages that MSM employs, only its high permissible contact pressure can NOT be put into use.

All other advantages remain, as there are its superior performance in accumulated sliding displacement and sliding velocity, and its excellent behaviour at cold temperatures, employing a considerably lower coefficient of friction than PTFE.

National Approval of MSM

.This National Approval states that ...

MAURER - MSM® - spherical bearings are particularly suitable for soft structures with relatively large and frequent displacements caused by traffic, next for structures that employ fast sliding displacements of the bearings, like in bridges for high speed railways, as well as for regions of continuously low temperatures.

No other sliding material is explicitly rated as being as suitable as MSM for the use in railway bridges.

Low and high temperatures

According to ETA, the MSM®-scope of application reaches from -50°C to +48°C. This has different consequences at high and low temperatures. Deep temperatures increase the friction and therefore put strain onto the bridge bearings. The design value of the coefficient of friction of MSM® is 2% in case of a temperature above -35°C, for PTFE we have 3%. In case of a temperature as low as -50°C, for MSM® we have 2.7%, and PTFE cannot be used. Thus, MSM® is the only sliding material that can be used at continuous temperatures of as low as -50°C.

The resistance to creep of MSM® is much higher compared to that of PTFE (Teflon). As a matter of fact very few European bearings manufacturers take into account the following requirement specified in the EN 1337: Structural Bearings – Part 2:

6.6 Design compressive strength for sliding materials

.....
 Values listed in Table 10 are valid for effective bearing temperatures up to 30°C.

For bearings exposed to a maximum effective bearing temperature in excess of 30°C and up to 48°C the afore-mentioned values shall be reduced by 2 % per degree above 30°C in order to reduce creep effects of PTFE.

.....
 The above means that for the effective temperature of 37 °C (which is the max. temperature to take into account in Germany) the PTFE pressure shall be reduced by 14%.

This is equivalent to design a pot bearing suitable for applications up to 30°C with a 14% increased vertical load capacity, which finally results in a cost raise of up to 15%.

The above represents just one of the non-compliances with the requirements specified in the European Norms usually encountered in the PTFE pot bearings.

Conversely, MSM®-Spherical Bearings from MAURER are certified by EOTA for their use up to temperatures of 48°C. This depends on the fact that creep behaviour of PTFE at 30°C corresponds to the creep behaviour of MSM® at 70°C.

It should be noted that extrusion of PTFE sheets due to excess of creep is one of the most common causes of pot bearings malfunctioning



Figure 2: Effects of creep in a PTFE sliding bearing

MSM or PTFE ?

Having highlighted the fact that MSM displays superior wear characteristics, there remains certainly a wide range of applications where the use of PTFE as sliding material is totally

acceptable. This section undertakes to classify the various bridge structures into use categories according to the accumulated horizontal sliding displacement of bridge bearings, such as to indicate for the designer of the bridge whether PTFE is still acceptable as sliding material, or MSM has to be given preference.

For the determination of the long term characteristics of a bridge bearing, it is not the magnitude of the individual movement that plays a deciding role, but the accumulated rotations and displacements that can be expected during the life time of a bridge bearing. In this respect the displacement of the structure due to temperature, creep and shrinkage only plays a minor role. Of deciding relevance are displacements and displacement velocities due to live loads. However, to date only few statistical data are available for consequent applications. In this respect, it has to be distinguished between the influences due to rotation and influences due to displacement of the superstructure at the support.

Due to the deflections of the girder and the rotations at the support, also displacements will be the consequence, which are a function of the distance between bridge bearing and the centre of rotation, which usually lies in the axis of gravity of the structure. These displacements create themselves again displacements in the horizontal sliding surfaces or fatigue relevant shear deformations in elastomeric bearings. In

particular in bridges for high speed railways and in case of soft wide span structures, e.g., suspension bridges, accumulated sliding displacements can occur that by far exceed the 10,000m which are defined in the approval tests of PTFE in main sliding surfaces).

Classification of structures

In respect to the suitability of sliding bearings, structures have to be distinguished according to their mode of usage (road bridge, rail bridge), the material employed (reinforced concrete, prestressed concrete, steel, composite) as well as the static system (single girder or continuous girder, arch bridge, cable stayed bridge, suspension bridge). For each of the aforementioned modes of combination, depending on the span width and the distribution of traffic load there will be an accumulated sliding displacement and rotational angle, which can be used for further judgment. The graphs below display the maximum rotational differences $\Delta\alpha_i$ and the sliding displacement per passing as a function of construction mode and span width. Thereby, for the design of the rail bridges the design load UIC 71 was applied, and for road bridges 60% of the design load truck SLW60 (60 tons) of DIN1072, which roughly corresponds to the fatigue design model 3 of EN 1991-2. In both cases thus we have design loads that are relevant for fatigue design.

--	--

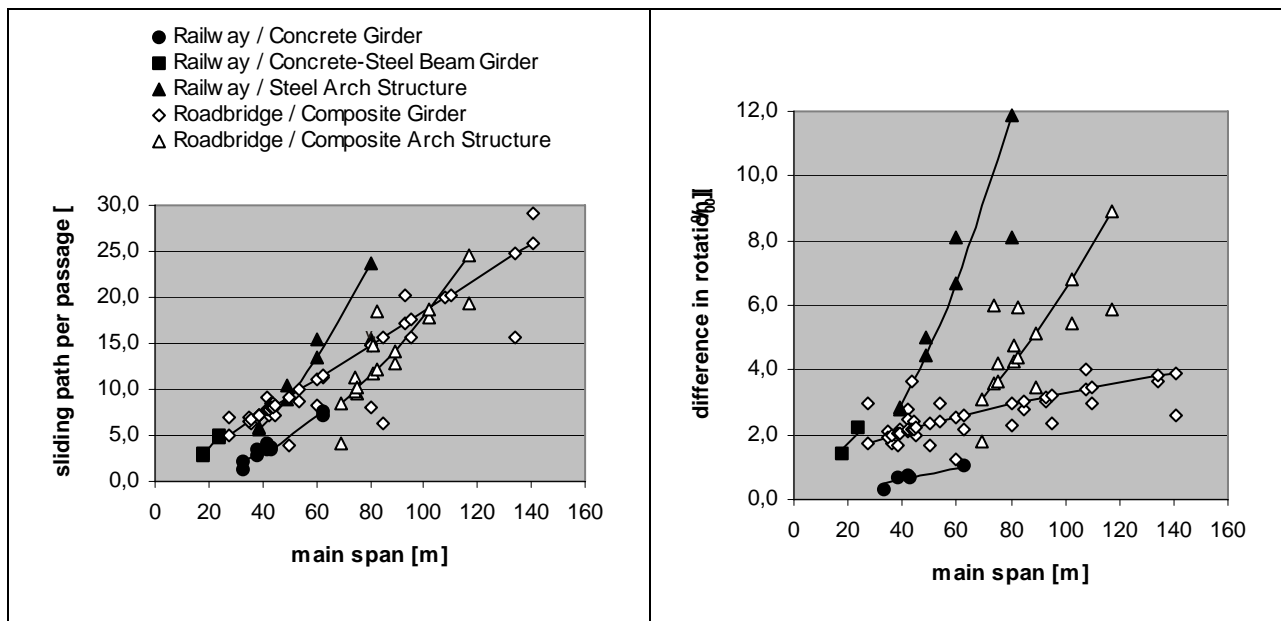

Fig 2.5: Support deformations due to traffic load

In case of rail bridges and $7.5 \cdot 10^4$ passings per year (standard mix of traffic according to EN 1991-2), a span width of 75 m, and a sliding displacement of 25 mm per passing, this corresponds to an accumulated sliding displacement of 2.0 km. If we assume the related rotational difference to be 10 %, and if we use for example a diameter DE of 1,000 mm or a radius R of the calotte (i.e. sphere) to be 500 mm, the resulting sliding displacement due to rotation calculates to 0.5 km. This results in a combined accumulated sliding displacement of about 2.5 km per year.

Thus, at the hands of the annual passings per year, and a maximum tested accumulated sliding path of 10,242 m for PTFE, the PTFE would last about 4 years, and MSM – with 50 km tested – would last around 20 years.

2.3 Sealing Elements in Pot Bearings

Under high pressure, the elastomeric pad in the pot behaves like an incompressible fluid, that attempts to protrude out of the pot through the clearance that is left between the wall of the pot and the lid. Sealing elements have to prevent such kind of “leakage”, while being flexible enough to follow the movements of the elastomeric pad when compressed.

When the sealing element is in contact with the inner steel wall and performs movements up and down the wall due to rotation of the elastomeric pads, friction will occur between the sealing elements and the inner steel wall. Depending on the friction coefficient, the sealing elements will be subjected to wear, thus having a limited service life time.

In railway bridges, where loads are relatively high, considerable rotations of the elastomeric pad are caused by passing train traffic. These rotations can be translated into up and down movements of the sealing elements, which add up over passing time to an accumulated sliding displacement.

At the European level, EN 1337-5 specifies the types of material available for sealing elements, and their maximum sliding displacement:

Sealing Material	Accumul Sliding Path	Category acc. EN 1337-5
Stainless Steel	500 m	a
Brass Seal	1,000 m	b
POM	2,000 m	c
Carbon PTFE	2,000 m	c

Table 2.3 Classification of Sealing Elements according to EN 1337-5

Apparently, for a big accumulated sliding path, sealing elements

made of POM or carbon filled PTFE are best suited for a long service life.

Example

The vertical displacement e is the product between the radius r of the elastomeric pad and the rotational angle ϕ . If we assume the elastomeric pad to perform a rotational angle of $\phi = \pm 0.002$, and the radius of the elastomeric pad is 300 mm, each time a train passes, the respective sliding path can be calculated as

$$e = 4 \phi r = 4 \times 0.002 \times 300 \text{ mm} = 2.4 \text{ mm (factor 4 for continuous girders, "up-down-down-up")}$$

The service life thus can be defined by the number of trains that can pass, until the total sliding path is reached. Brass sealings would allow app. 417,000 passings, and carbon filled PTFE double that amount. Knowing the number of passings per year, the life time of the pot bearing finds its upper limit, when the sealing element is totally worn out and can no longer keep the elastomeric pad in the pot.

Since it is in the nature of railway bridges that the rotational angle of pot bearings is relatively large, the European Standard EN1337-5 prohibits the use of sealing elements made of brass or stainless steel in pot bearings for railway bridges, because they do not pass the mandatory requirement of

2,000 m of accumulated sliding path.

The sealing element that Maurer Söhne employs is a carbon filled PTFE and thus falls into category “c”, thus being suitable for the use in pot bearings for railway bridges.

2.4 Elastomeric Bearings

In chapter 804.5101, the specification „Ri804“ of German Railways (DB) regulates the use of bridge bearings in railway bridges.

In respect to the elastomeric bearings that are to be used in railway bridges, certain design features have to be observed:

1. Elastomeric bearings that are subject to horizontal forces need to be equipped with so called steel restrains that are designed to accommodate the horizontal forces.

Without such steel restrains, elastomeric bearings will not be accepted to transfer horizontal loads.

2. The contact surfaces for load transfer have to be machined
3. As for elastomeric bearings that are fixed in one direction, for structures of a length of more than 25 m the sliding partners of the elastomeric bearings have to

designed according to the provisions for sliding bearings.

It goes without saying that Maurer elastomeric bearings with steel restrains comply to the provisions of German Railways, as governed in the Ri804 specification.

Steel restrains are usually made of conventionally welded steel structures, designed for transferring horizontal loads.

The 2 figures below depict principle sketches of elastomeric bearings with steel restraint.

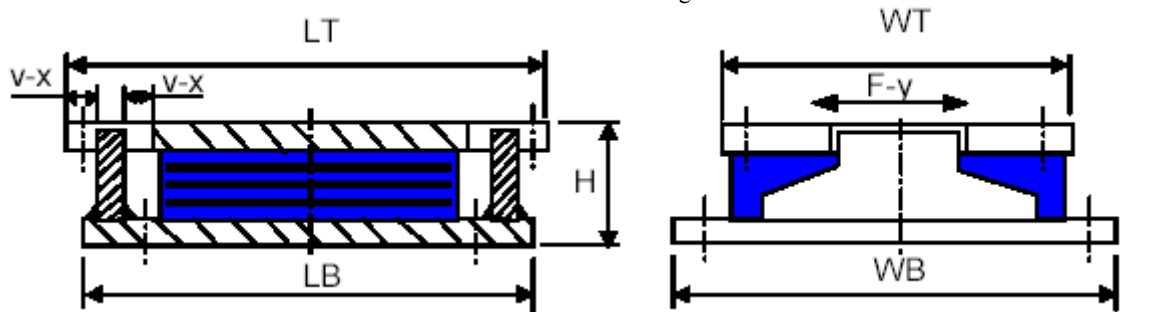

Fig. 2x Maurer Elastomeric Bearing of Type VI, fixed in one direction, movable in the other direction

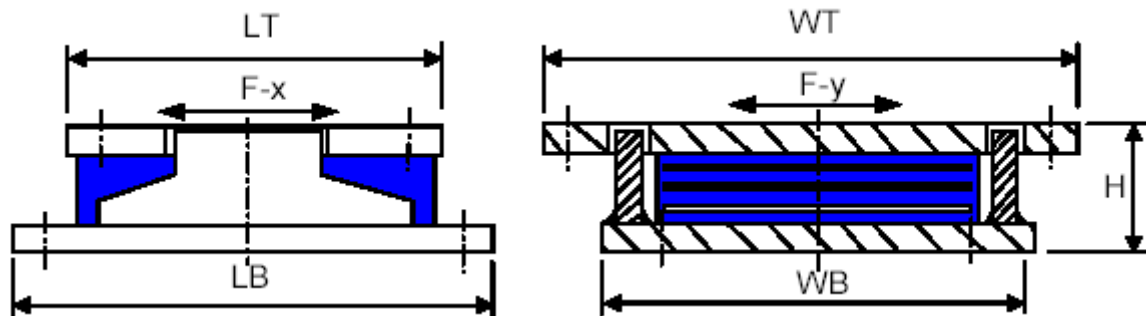

Fig. 2.x Maurer Elastomeric Bearing of Type V, fixed in both directions

3. Force Delimiters – High Performance STU’s

Shock Transmitters (STU’s), or Lock-Up-Devices (LUD’s), or Rigid Connection Devices (RCD’s), or Seismic Connectors, or Buffers, all are different names for the same product, serving a certain performance requirement. If all of a sudden loads, displacements or energy input caused by earth quake are introduced into a bridge structure, care has to be taken that the structure that is suddenly exposed to that attack does not succumb to the excess strain that it may be exposed to. For that end, shock transmission units are introduced

that are designed to rigidly link separate partial structures and unite the partial structures into one big structure, thus enabling the total structure to take care of the attack simultaneously, distributing the effects of the attack equally over the total structure.

The trigger when such shock transmitters are enacted is the velocity of the attack. Small movements caused by thermal extension or contraction, or shrinkage, or creep, go unnoticed by the STUs, and the structure behaves as if the STUs wouldn’t be there.

However, when a certain trigger velocity is surpassed, all off a sudden the STU will behave like a stiff coupler between partial

structures, thus deserving its name “shock transmission unit”.

This way, the capacity of the total structure to store elastic as well as kinetic energy is increased.

In railway bridges, apart from attacks caused by earthquake which might be relatively rare, a rather more likely occurrence might be braking forces of the train that are suddenly induced into the bridge structure, causing a high displacement velocity. The STU will enact its function, coupling adjacent fields such that every pier will have to receive an equal share of the horizontal load.

So goes the theory.

In reality, the piers may not be constructed all alike, the shock transmission units may not be installed exactly identically, or other tolerances in construction will distort the image of an ideally decoupled structure under identical stiffness, which, once the STU's come into action, will all receive exactly their calculated share of the horizontal load.

Rather, due to such tolerances in construction, the load distribution might not be equal. For example, because of being stiffer due to whatever reason, some piers might get an undue share of the horizontal load, and will have to deflect much more until they can pass over their (horizontally acting) load to the adjacent pier. In a worst case, even when applying an STU, when an individual structural member defaults due to excess strain, the total structure may then be endangered, because the same high longitudinal force now has to be accommodated by fewer piers, causing perhaps the next pier to default.

Reason for such default is that the conventional STU closes at a certain velocity, but does not open in case the force to be transmitted exceeds the design force in ultimate limit state.

This is why the MAURER MSTL (Maurer Shock Transmitter with Limiter) was developed.

A MAURER MSTL is a shock transmission unit with a force delimiter. Thus the STU makes sure that only a certain design force can be transferred. Once the actual horizontal force to be transferred would exceed the design force, the STU "opens" and starts to move, allowing the forces to be transferred to adjacent piers, or the abutment. For example, a MAURER MSTL can be designed such that it can transfer to the pier a maximum of 120% of the design force, as the graph below illustrates.

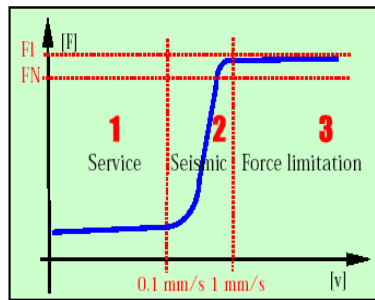

Fig:3.1 Example of a force-velocity relation of an MSTL (same holds for an MHD, see below)

For the pier this means that the maximum horizontal force it has to accommodate is clearly defined. With such a clear definition of the maximum horizontal force, the safety concept for the pier can be optimised in a way that the pier itself need not be designed for more than these exemplary 120% of horizontal loads. Savings in concrete and reinforcement steel usually by far outweigh the additional costs of procuring a MAURER MSTL.

A MAURER MSTL also cannot any longer be categorised into the standard world of STU's. A force limiter is like a buffer with a safety valve – when it moves it also dissipates energy, thus functioning as a damper.

A Maurer Shock Transmitter can also be integrated into the design of bridge bearings, as the following sketch illustrates.

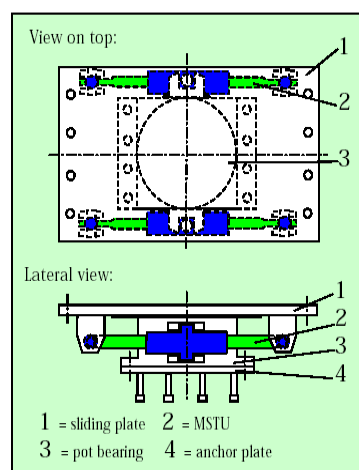

Fig.3.2 Integration of an MSTU with a pot bearing

3.2 Reference Project of an MSTL

The photograph below depicts a 2,500 kN MSTL for the railway viaduct De La Rambla in Spain.



Fig. 33 A 2,500 kN MSTL for the railway viaduct De La Rambla, Spain

3.3 Installation

2 installation modes are possible, as the following 2 illustrations depict:

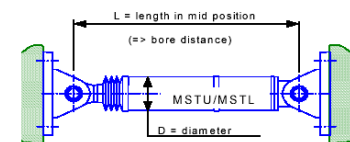

Fig. 3.3 Position mainly used for abutments

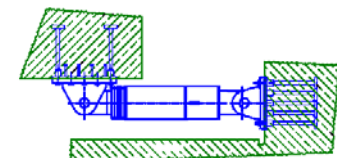

Fig.4.4 Position mainly used for piers

3.4 Dimensions of Maurer MSTU/MSTL

Table 3.1 depicts the diameter D and the length L of a MSTU or MSTL, depending on the force and the stroke.

The length excludes the space required for the anchoring devices, which also may be supplied by third parties.

These standard dimensions can be adapted to the requirements of the client.

4 Maurer Hydraulic Dampers (MHD)

4.1 General

Like a shock transmission unit (STU), a damper has no effect onto the bridge structure when the movement velocity of the bridge deck is small, like when being caused by thermal effects, or shrinkage, or creep. However, apart from this common characteristic, a damper serves a

fundamentally different purpose to the one of an STU

When the movement velocity exceeds a certain threshold to be defined by the designer, a damper starts to move (thus doing the opposite to an STU that “locks up” the structure), and by way of moving, a damper will dissipate energy. Earth quake is a case in point when dampers have to perform their function.

The Maurer Hydraulic Damper (MHD) was developed following the Energy Approach Concept. According to the Energy Approach, a seismic attack is no longer considered to represent forces that attack the structure, but it is rather a kind of “energy shock” that a structure has to deal with. Thinking of excess energy that attacks the bridge structure, devices have to be developed that “swallow”, or in scientific terms, dissipate the energy, thus protecting the bridge structure from collapse or major damages. Simply speaking, the bigger the “stomach” of the device to swallow this energy, the better its capacity to protect the structure. To stay in this picture, Maurer has developed the device with the biggest “stomach” so far in the market, in terms of energy dissipating capacity. The energy dissipated will then be converted into heat.

4.2 A brief technical description

Energy dissipated is a product of the response force F and the displacement s of the piston of the damper. The response force F is thereby governed by the following formula

$$F = C \cdot v^\alpha$$

Whereas

F = the response force of the MHD

C = Constant value

v = displacement velocity (can be as much as 1.4 m/sec)

α = damping exponent (for an MHD, depending on type, between 0.02 and 0.04)

The special feature of an MHD is the very small α -value, which relies an MHD this high energy dissipating characteristic. The smaller this value, i.e. the closer to zero, the more the expression v^α

will turn into a constant “1”, and as a result the response force F will be independent of the displacement velocity v .

This effect relies an MHD another distinctive characteristic: The response force is practically constant, independent of the displacement velocity. By virtue of this being constant, a designer can make sure that, no matter how strong the “design earthquake” will be, the response force cannot exceed its limit, and thus the response force that is introduced into the structure is constant, no matter how strong the earth quake is. The case would be different if the α -value would be bigger, like for example 0.3, as it is the case in many conventional dampers on the market. In that case, once the displacement velocity would exceed its design limit, the response force also would exceed its design limit, thus inflicting higher forces into the structure, which have to be taken care of. In other words, a higher α -value translates to less safety for the structure. Or, in order to keep the safety constant, bigger dampers have to be employed.

The force-velocity relationship of an MHD that employs a very low α -value of about 0.02 is very similar to the one of an MSTL, as it is displayed in Fig.3.1. Until to a certain threshold – here 0.1 mm/sec – the MHD remains largely inactive, employing a nominal response force only (Phase 1). Then, the response force rises with increasing velocity to its maximum (defined) value of F_N which is reached at 1 mm/sec (Phase 2), and after exceeding the 1 mm/sec velocity, this response force remains almost constant, that is it rises to the insignificantly bigger response force F_I . The smaller the α -value, the smaller the increase of F_I over F_N .

In the case of suddenly acting braking forces or acceleration, an MHD can be additionally designed to act like a STU. In the above example, this velocity range where the MHD works as an STU – phase 2 - is between 0.1 mm/sec and 1 mm/sec. Above a movement velocity of 1 mm/sec, the movement is considered to originate from a seismic attack,

and consequently the damping function is taking effect (Phase 3).

So, generally speaking, and apart from details, an MSTL and an MHD are different terms for the same hardware, which has a hybrid function. Only, whereas an MSTL has by design to work in phase 2, the MHD has its job to be accomplished in phase 3.

This points to the main characteristic of a hybrid Maurer MHD or MSTL. A customer who decides to use a Maurer MHD respectively an MSTL will be provided with a complementary function. In case of an MHD, it is the additional buffer functionality that the damper employs, and in case of an MSTL it is the safety valve against overloads.

4.3 Reference Projects

The Seyhan River Bridge in Adana / Turkey is a bridge for a Mass Transit Railway and had to be protected against seismic attacks. Maurer installed 4 MHDs of a capacity of 1,000 kN each. These dampers also act like an STU within well defined velocity limits.



Fig4.2 A 1,000 kN MHD at the Seyhan River Bridge, Adana, Turkey

Due to the nature of the bridge – a railway bridge – dampers could only be installed in longitudinal direction. In transverse direction, the owner did not permit any movement because of the rails, and so pot bearings had to transfer to corresponding horizontal forces.

The MHDs employed limited the maximum movement in loading case earth quake to +/- 35 mm. In case of such a “design earth quake”, no repair works need to be carried out.

Standard Dimensions of MSTU and MHD

axial force [kN]	maximum stroke [+/-mm]													
	50		100		150		200		250		300		400	
	D [mm]	L [mm]	D [mm]	L [mm]	D [mm]	L [mm]	D [mm]	L [mm]	D [mm]	L [mm]	D [mm]	L [mm]	D [mm]	L [mm]
50	110	690	110	970	110	1250	110	1530	110	1810	110	2000	110	2550
100	120	720	120	1000	120	1280	120	1560	120	1840	120	2030	120	2580
200	180	760	160	1040	180	1320	180	1600	180	1880	180	2070	180	2620
500	195	790	195	1070	195	1350	195	1630	195	1910	195	2100	195	2650
750	215	805	215	1085	215	1365	215	1645	215	1925	215	2115	215	2665
1000	235	825	235	1105	235	1385	235	1665	235	1945	235	2135	235	2685
1250	280	890	280	1170	280	1450	280	1730	280	2010	280	2200	280	2750
1500	295	990	295	1270	295	1550	295	1830	295	2110	295	2300	295	2750
1750	325	1045	325	1325	325	1605	325	1885	325	2165	325	2295	325	2805
2000	365	1210	365	1490	365	1770	365	2030	365	2330	365	2400	365	2870
2500	405	1320	405	1600	405	1880	405	2140	405	2400	405	2540	405	2980
3000	455	1440	455	1680	455	2000	455	2260	455	2400	455	2660	455	3100
4000	505	1555	505	1795	505	2115	505	2375	505	2555	505	2775	505	3215
5000	540	1840	540	2080	540	2400	540	2660	540	2840	540	3060	540	3500
6000	590	2090	590	2330	590	2650	590	2910	590	3090	590	3310	590	3750

Table 3.1 Standard dimensions of a Maurer MSTU/MSTL

The table below depicts the standard dimensions of a Maurer MHD damper.

axial force [kN]	maximum stroke [+/-mm]													
	50		100		150		200		250		300		400	
	D [mm]	L [mm]	D [mm]	L [mm]	D [mm]	L [mm]	D [mm]	L [mm]	D [mm]	L [mm]	D [mm]	L [mm]	D [mm]	L [mm]
50	110	740	110	1020	110	1300	110	1580	110	1860	110	2050	110	2600
100	120	770	120	1050	120	1330	120	1610	120	1890	120	2080	120	2630
200	180	810	160	1090	180	1370	180	1650	180	1930	180	2120	180	2670
500	195	850	195	1130	195	1410	195	1690	195	1970	195	2160	195	2710
750	215	865	215	1145	215	1425	215	1705	215	1985	215	2175	215	2725
1000	235	885	235	1165	235	1445	235	1725	235	2005	235	2195	235	2745
1250	280	960	280	1240	280	1520	280	1800	280	2080	280	2270	280	2820
1500	295	1060	295	1340	295	1620	295	1900	295	2180	295	2370	295	2820
1750	325	1125	325	1405	325	1685	325	1965	325	2245	325	2375	325	2885
2000	365	1290	365	1570	365	1850	365	2110	365	2410	365	2480	365	2950
2500	405	1410	405	1690	405	1970	405	2230	405	2490	405	2630	405	3070
3000	455	1530	455	1770	455	2090	455	2350	455	2490	455	2750	455	3190
4000	505	1645	505	1885	505	2205	505	2465	505	2645	505	2865	505	3305
5000	540	1940	540	2180	540	2500	540	2760	540	2940	540	3160	540	3600
6000	590	2190	590	2430	590	2750	590	3010	590	3190	590	3410	590	3850

Table 4.1 Standard dimensions of a Maurer MHD



Maurer Söhne Head Office
Frankfurter Ring 193, D-80807 München
P.O. Box 44 01 45, 80750 München/Germany
Phone ++49/89/32394-0
Fax ++49/89/32394-306
e-mail ba@mchn.maurer-soehne.de
Internet www.maurer-soehne.de

Maurer Söhne Main Branch Office
Zum Holzplatz 2, D-44536 Lünen
P.O. Box 63 40, D-44520 Lünen
Phone ++49/231/43401-0
Fax ++49/231/43401-11

Maurer Söhne Subsidiary Plant
Kamerzer Str. 4-6, D-02994 Bernsdorf
P.O. Box 55, D-02992 Bernsdorf
Phone ++49/35723/237-0
Fax ++49/35723/237-20